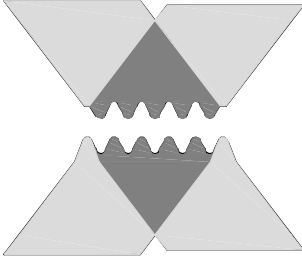
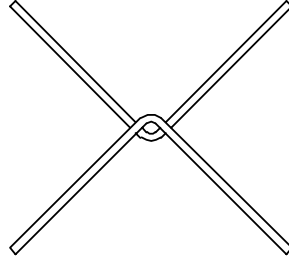


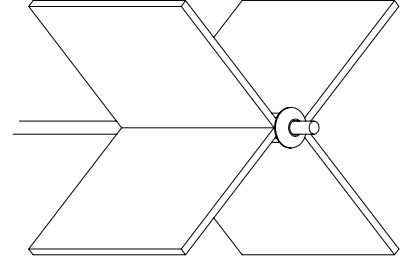
## INSTALLATION



Vanes as supplied in interlocking pairs, the paired vanes having five and six knuckles respectively.

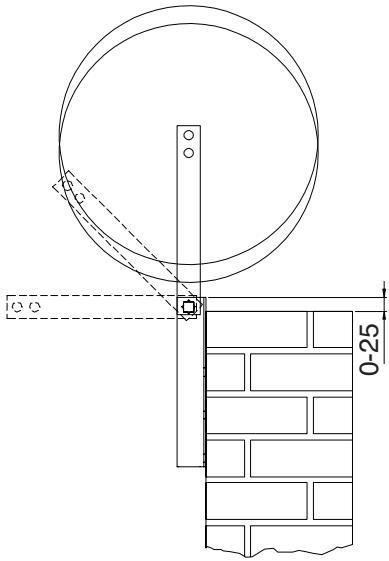


Paired vanes interlocked.

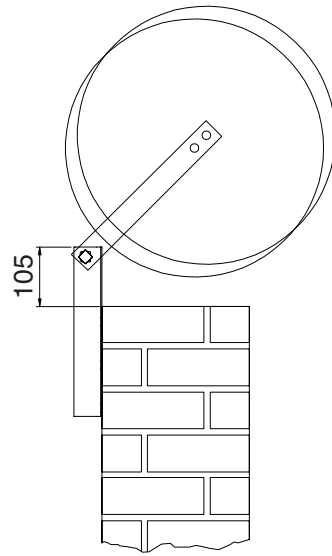


Vanes with spindle inserted.

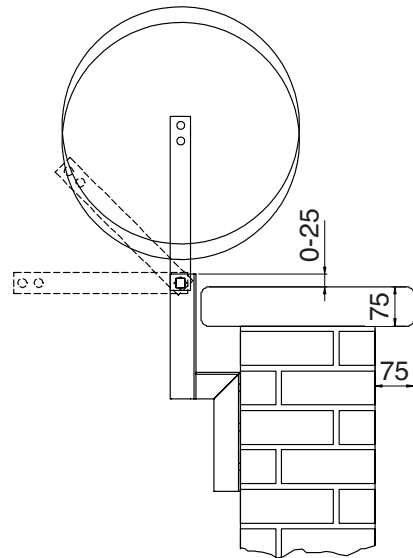
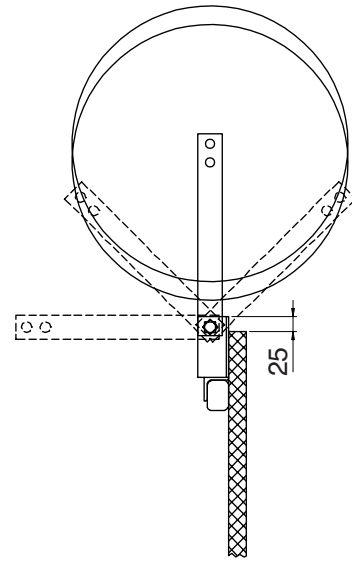
**POSSIBLE ARRANGEMENT OF TOP-ARMS USING STANDARD FIXING BRACKETS. OTHER FIXING BRACKETS MADE TO ORDER.**



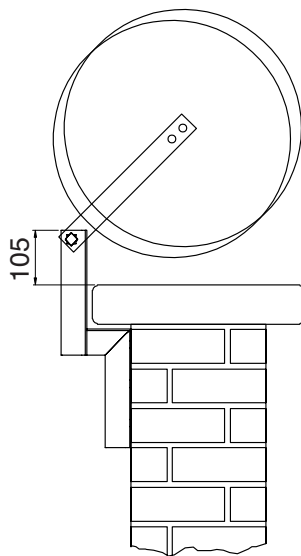
Wall fixing bracket



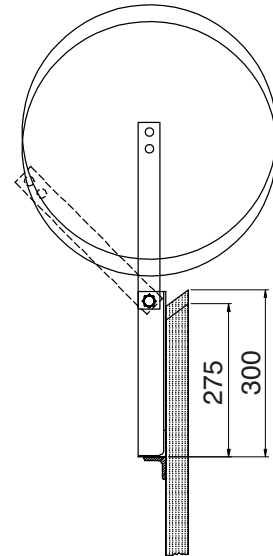
Fence fixing bracket



Coping stone bracket

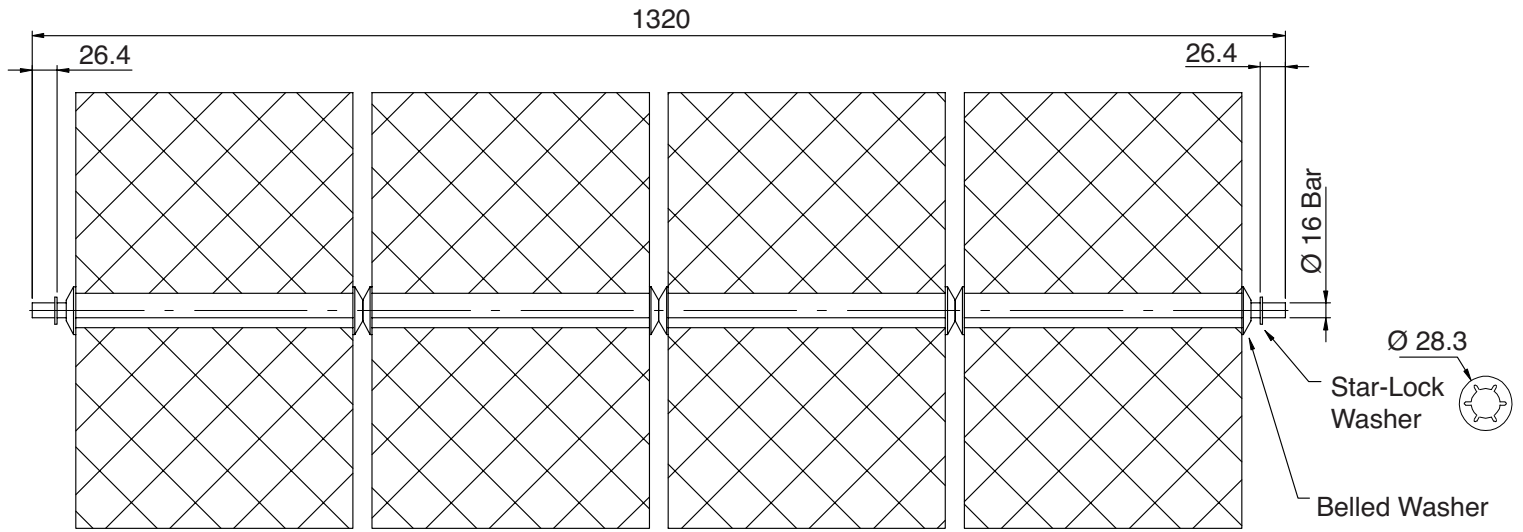


Palisade fixing bracket

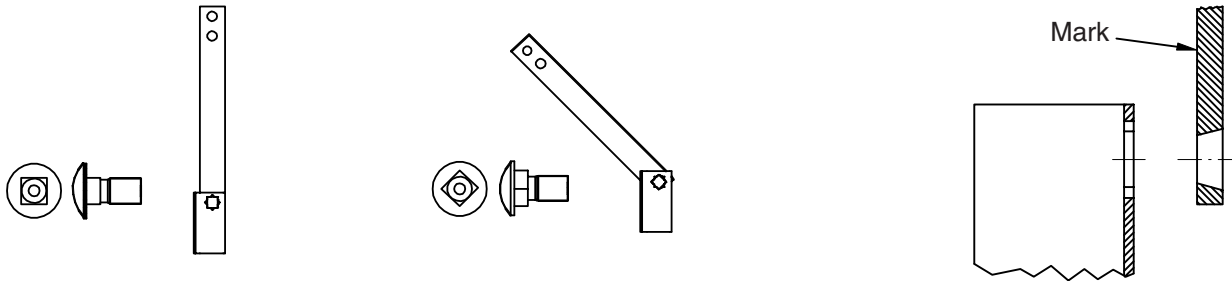


**WARNING:  
SHARP EDGES!  
ALWAYS WEAR PROTECTIVE GLOVES & HELMET**

**FIGURE 1:**



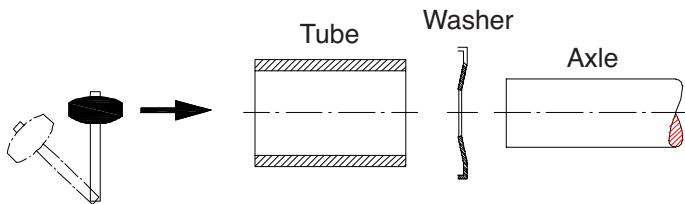
**FIGURE 2:**



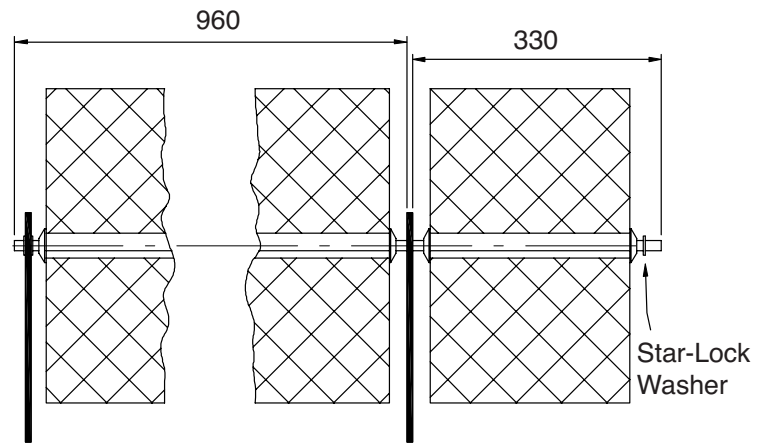
The bolt's square neck position adjusts the angle of the top-arm.

Top-arm is attached from the side with the mark (a circle).

**FIGURE 3:**

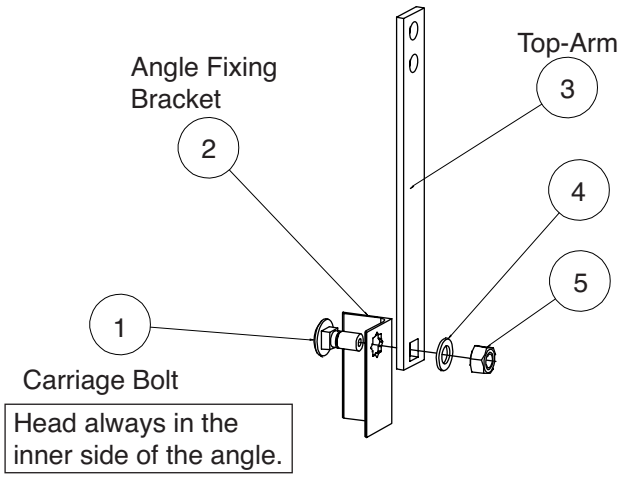


**FIGURE 4:**

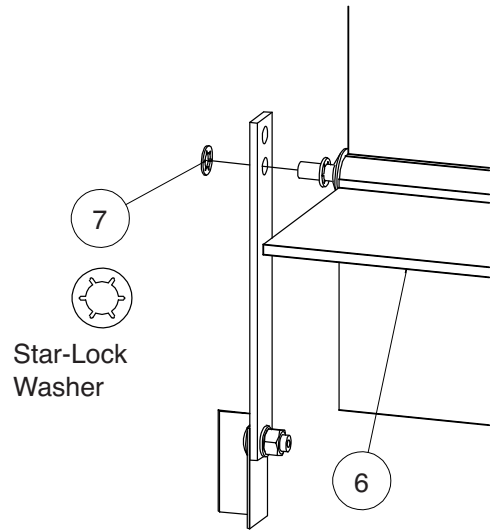


If short runs are required or top-arms need to be positioned between Raptor units, you must ensure that a star-lock washer is positioned on the end of the spindle.

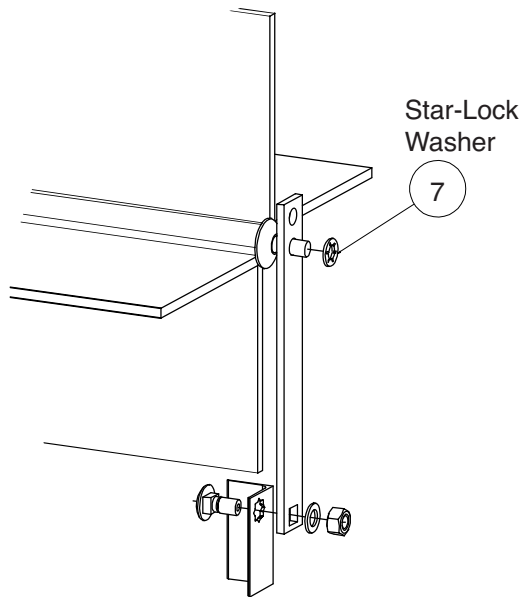
**PHASE 1:**



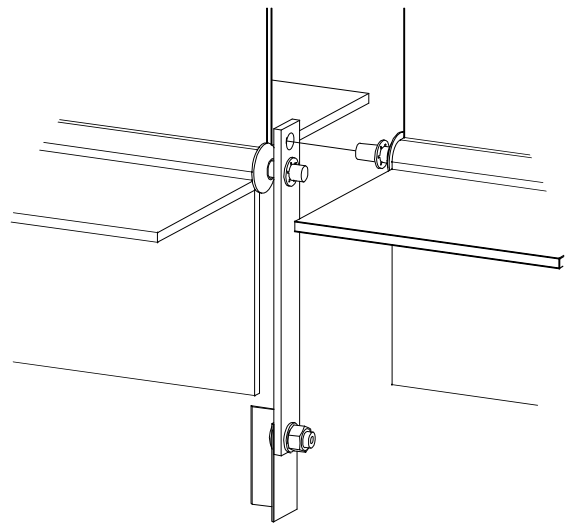
**PHASE 2:**



**PHASE 3:**



**PHASE 4:**



1. Install angle-fixing brackets at 1280mm centres.
2. Using a carriage bolt as shown in Fig 2, attach top-arm bracket to angle-fixing bracket as shown in PHASE 1.
3. Take pre-assembled AVSB spindle, fix to one of top-arm holes and secure with a star-lock washer as shown in PHASE 2 . Star-lock washers can be fixed using a 3/4" socket or a D26.9 x 3.2 mm tube (Outside Diameter x Thickness) - [Not Supplied]. See Fig 3
4. Attach top-arm bracket to angle-fixing bracket and to the other end of AVSB spindle (same hole as first end) and secure with a star-lock washer as shown in PHASE 3.
5. Take pre-assembled AVSB spindle and fix to the free top-arm hole as shown in PHASE 4. No star-lock washer there.
6. As step 4.
7. For short runs see Fig. 4

PARTS LIST	
A/N	Description
1	Round head square neck bolt
2	Angle-fixing bracket
3	Top-arm
4	Washer (3mm thick)
5	Hex nut
6	AVSB bay
7	Star-lock washer

Whilst every effort has been made to ensure the accuracy of the information supplied. F.H.Brundle cannot be held responsible for any errors or omissions. This product must only be employed for its original intended use. Any other use is wrong and potentially dangerous. Installation must be carried out in full compliance with current regulations. F.H.Brundle cannot be held liable for any damages resulting from wrongful, erroneous or negligent use.

<b>Southampton</b> Tel: 023 8070 3333 Fax: 023 8070 5555	<b>Rainham</b> Tel: 01708 25 35 45 Fax: 01708 25 35 50	<b>Ilkeston</b> Tel: 0115 930 2070 Fax: 0115 951 2455	<b>Birmingham</b> Tel: 0121 565 8282 Fax: 0121 565 8292	<b>Haydock</b> Tel: 01942 86 88 88 Fax: 01942 86 88 99	<b>Edinburgh</b> Tel: 0131 335 5999 Fax: 0131 335 5911	<b>Glasgow</b> Tel: 0141 332 3231 Fax: 0141 332 7325
--	--	---	---	--	--	--



**F.H. BRUNDLE**  
SERVING THE TRADE SINCE 1889

[www.fhbrundle.co.uk](http://www.fhbrundle.co.uk)  
[sales@brundle.com](mailto:sales@brundle.com)